

WELDING PARTS, CONTRACT MACHINING, AND RESPONSIVENESS

1-800-558-5213 414-421-8890 FAX 414-421-8896

CUSTOMIZED WELDING PARTS TEMPLATE

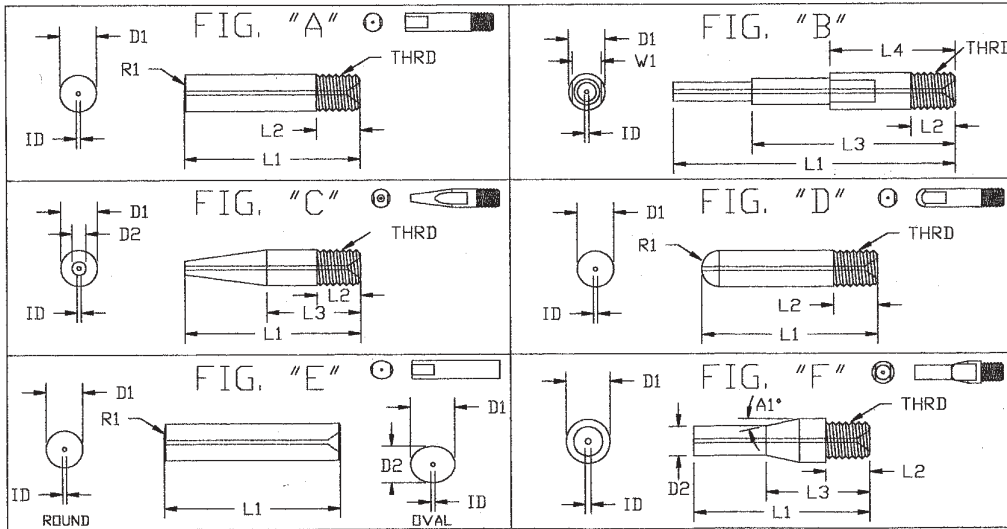

GEOMETRY	STYLE	D1	ID	D2	D3	L1	L2	L3	L4	THREAD	A1	R1	WRENCH
○ ○ ○	OF TIP	(OD)	OR WIRE										FLATS YES/NO
	FIG. "A"												
	FIG. "B"												
	FIG. "C"												
	FIG. "D"												
	FIG. "E"												
	FIG. "F"												
	SPECIAL												

SKETCH YOUR OWN TIP

PLEASE SPECIFY QUANTITY AND MATERIAL FOR QUOTING:

QUANTITY

MATERIALS

COPPER STANDARD 122 _____

BERYLLIUM CLASS 3 COPPER _____

COPPER CHROME ZIRCONIUM _____

OTHER _____

WE'LL QUOTE IT FAST! FAX IT TO 414-421-8896